

# PRODUCT INFORMATION PACKET

Model No: 284TTDN16101  
Catalog No: H188B  
10,900,DP,284T,3/60/230/460  
Open Drip Proof (ODP)



Regal and Marathon are trademarks of Regal Beloit Corporation or one of its affiliated companies.  
©2018 Regal Beloit Corporation, All Rights Reserved. MC017097E



### Nameplate Specifications

Output HP	<b>10 Hp</b>	Output KW	<b>7.5 kW</b>
Frequency	<b>60 Hz</b>	Voltage	<b>230/460 V</b>
Current	<b>29.0/14.5 A</b>	Speed	<b>880 rpm</b>
Service Factor	<b>1.15</b>	Phase	<b>3</b>
Efficiency	<b>90.2 %</b>	Duty	<b>Continuous</b>
Insulation Class	<b>F</b>	Design Code	<b>B</b>
KVA Code	<b>G</b>	Frame	<b>284T</b>
Enclosure	<b>Drip Proof</b>	Overload Protector	<b>No</b>
Ambient Temperature	<b>40 °C</b>	Drive End Bearing Size	<b>6311</b>
Opp Drive End Bearing Size	<b>6210</b>	UL	<b>Recognized</b>
CSA	<b>Y</b>	CE	<b>Y</b>
IP Code	<b>23</b>		

### Technical Specifications

Electrical Type	<b>Squirrel Cage Induction Run</b>	Starting Method	<b>Across The Line</b>
Poles	<b>8</b>	Rotation	<b>Reversible</b>
Mounting	<b>Rigid base</b>	Motor Orientation	<b>Horizontal</b>
Drive End Bearing	<b>Ball</b>	Opp Drive End Bearing	<b>Ball</b>
Frame Material	<b>Cast Iron</b>	Shaft Type	<b>T</b>
Overall Length	<b>24.94 in</b>	Frame Length	<b>13.25 in</b>
Shaft Diameter	<b>1.875 in</b>	Shaft Extension	<b>4.83 in</b>
Assembly/Box Mounting	<b>F1/F2 Capable</b>		
Outline Drawing	<b>B-SS207936-1325</b>	Connection Diagram	<b>A-EE7308</b>

This is an uncontrolled document once printed or downloaded and is subject to change without notice. Date Created: 07/02/2018

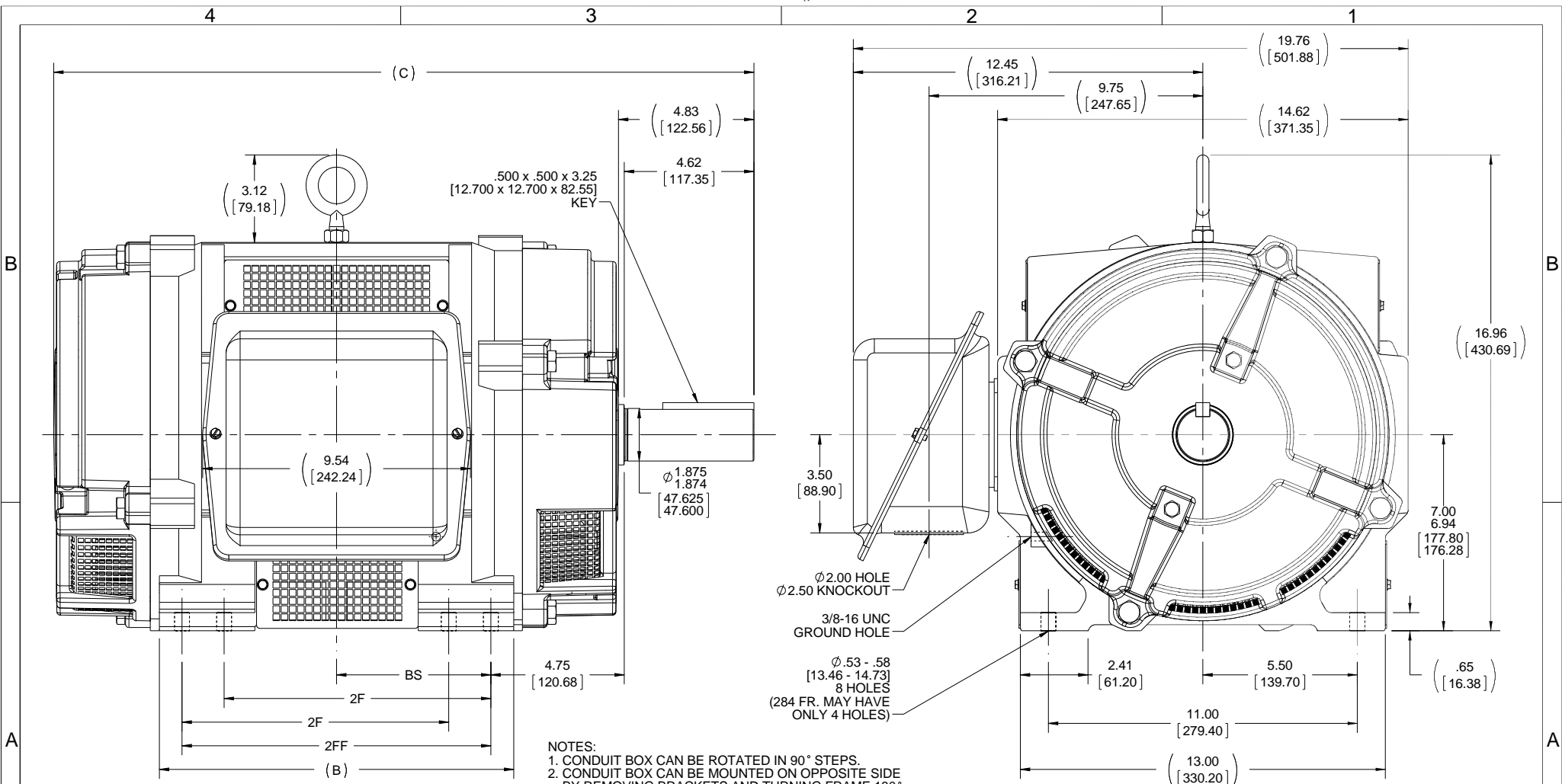

- NOTES:
1. CONDUIT BOX CAN BE ROTATED IN 90° STEPS.
  2. CONDUIT BOX CAN BE MOUNTED ON OPPOSITE SIDE BY REMOVING BRACKETS AND TURNING FRAME 180°.
  3. NAMEPLATE TO BE READ FROM CONDUIT BOX SIDE OF MOTOR.

DASH	FRAME	B	C	2F	2FF	BS
1275	284T	11.75 [298.45]	24.44 [620.78]	---	9.50 [241.30]	4.75 [120.65]
1325	284T/ 286T	12.62 [320.55]	24.94 [633.48]	9.50 [241.30]	11.00 [279.40]	5.50 [139.70]
1512	286T	14.50 [368.30]	26.81 [680.97]	11.00 [279.40]	---	6.44 [163.58]

DRAWING REVISION C	REVISION BY J. OTTO	DATE 06-28-2016
ECO ECO-0104805	APPROVED BY T. BROWN	DATE 06-29-2016
ECO DESCRIPTION UPDATED TITLE BLOCK		
<small>COPYRIGHT REGAL BELOIT AMERICA, INC. ALL RIGHTS RESERVED.          PROPRIETARY AND CONFIDENTIAL INFORMATION - THIS DOCUMENT IS THE PROPERTY OF          REGAL BELOIT AMERICA, INC. ('OWNER') AND CONTAINS OWNER'S PROPRIETARY          INFORMATION. ANY PERSON, CORPORATION OR OTHER FIRM RECEIVING IT IS DEEMED,          BY RECEIVING IT, TO AGREE THAT IT, AND/OR ANY PART OF IT, SHALL NOT BE DISCLOSED          TO ANY PERSON, CORPORATION OR OTHER ENTITY, DUPLICATED, AND/OR USED, EXCEPT          AS EXPRESSLY APPROVED IN WRITING IN ADVANCE BY OWNER. THIS DOCUMENT SHALL          BE RETURNED TO OWNER UPON REQUEST. IT MAY BE SUBJECT TO CERTAIN          RESTRICTIONS UNDER APPLICABLE EXPORT CONTROL LAWS AND REGULATIONS.</small>		

TOLERANCES UNLESS OTHERWISE SPECIFIED:		
DEC.	INCH	mm
.X	±0.1	[±2.5]
.XX	±0.03	[±0.76]
.XXX	±0.005	[±0.127]
.XXXX	±0.0005	[±0.0127]
REMOVE BURRS & BREAK SHARP EDGES: .003/.015 [0.076/.381] X 45°		
CORNER FILLETS: R.02 [5.1]		
MACHINED SURFACES: 200 INCH 5.1 mm		
mm SHOWN IN [BRACKETS]		

DRAWN BY RJW
DATE 10-08-2007
APPROVED BY BW
DATE 10-09-2007
REFERENCE
THIRD ANGLE PROJECTION

Regal Beloit America, Inc.	
DESCRIPTION <b>OUTLINE</b> 280T FR. - DR. PR. - CAST IRON	
MATERIAL	PROCESS/FINISH
SIZE B	DRAWING NUMBER SS207936
	SHEET 1 OF 1

EE7308

THREE PHASE  
DUAL VOLTAGE MOTOR



VIEW OF TERMINAL END

REF.  
WINDING DIAGRAM

T8Y, T2Y, T2BL, T4BX, T2EC, T2G  
T6BZ, T2B, T6BL, T4AV, T6B, T4B

OPTIONAL CORD  
CONNECTION

L1 — WHITE  
L2 — RED  
L3 — BLACK

NO.	REVISION	BY & DATE	CHK	ANG	TOLERANCES UNLESS SPECIFIED		FINISH	DRAWN RM 11/20/1990				
					DEC.	INCHES						
5	CHG TO REGAL LOGO	SL 09/10/2015	AB					CHK ML 11/21/1990				
4	REVISED IEC NOTATIONS	MSG 11/15/2011	CMN	.X	±.1			APPD SAS 04/24/2003				
3	ADDED IEC NOTATIONS... (U1), (V1) ETC. MU95194	MSG 5/10/2010	MJS	.XX	±.02		TITLE CONNECTION DIAGRAM	SCALE 1=1				
2	ADDED THE OPTIONAL CORD CONNECTION MU46318	RDH 04/24/2003	DRS	.XXX	±.005		3Ø - DUAL VOLTAGE MOTOR	REF				
1	REDRAWN	RM 11/20/1990		.XXXX	±.0005		MAT'L.	FMF				
					±7'30"			PREV				
THIS DRAWING IN DESIGN AND DETAIL IS OUR PROPERTY AND MUST NOT BE USED EXCEPT IN CONNECTION WITH OUR WORK ALL RIGHTS OF DESIGN AND INVENTION ARE RESERVED THIS IS AN ELECTRONICALLY GENERATED DOCUMENT - DO NOT SCALE THIS PRINT							RFP	CAD FILE ee7308	SIZE A	DRAWING NO. EE7308	PAGE OF 5	REV. 5
							DIST WP					



**CERTIFICATION DATA SHEET**

**Model#:** 284TTDN16101 AA      **WINDING#:** K284848 NONE 1  
**CONN. DIAGRAM:** A-EE7308      **ASSEMBLY:** F1/F2 CAPABLE  
**OUTLINE:** B-SS207936-1325

**TYPICAL MOTOR PERFORMANCE DATA**

HP	KW	SYNC. RPM	F.L. RPM	FRAME	ENCLOSURE	KVA CODE	DESIGN
10&7 1/2	7.5&5.6	900	880&730	284T	DP	G	B

PH	Hz	VOLTS	FL AMPS	START TYPE	DUTY	INSL	S.F	AMB°C	ELEVATION
3	60/50	230/460#190/ 380	29/14.5&28/14	ACROSS THE LINE	CONTINUOU S	F3	1.15/1.0	40	3300

FULL LOAD EFF: 90.2&89.5	3/4 LOAD EFF: 90.2	1/2 LOAD EFF: 86.5	GTD. EFF	ELEC. TYPE	NO LOAD AMPS
FULL LOAD PF: 71&69	3/4 LOAD PF: 62	1/2 LOAD PF: 49.5	89.5	SQ CAGE IND RUN	16 / 8

F.L. TORQUE	LOCKED ROTOR AMPS	L.R. TORQUE	B.D. TORQUE	F.L. RISE°C
59.7 LB-FT	140 / 70	77 LB-FT 129	140 LB-FT 235	45

SOUND PRESSURE @ 3 FT.	SOUND POWER	ROTOR WK^2	MAX. WK^2	SAFE STALL TIME	STARTS /HOUR	APPROX. MOTOR WGT
63 dBA	73 dBA	4 LB-FT^2	- LB-FT^2	- SEC.	-	400 LBS.

**\*\*\* SUPPLEMENTAL INFORMATION \*\*\***

DE BRACKET TYPE	ODE BRACKET TYPE	MOUNT TYPE	ORIENTATION	SEVERE DUTY	HAZARDOUS LOCATION	DRIP COVER	SCREENS	PAINT
STANDARD	STANDARD	RIGID	HORIZONTAL	FALSE	NONE	FALSE	RODENT	BLUE (ENAMEL)

BEARINGS		GREASE	SHAFT TYPE	SPECIAL DE	SPECIAL ODE	SHAFT MATERIAL	FRAME MATERIAL
DE	OPE	POLYREX EM	T	NONE	NONE	1045 HOT ROLLED (C-204)	CAST IRON
BALL	BALL						
6311	6210						

THERMO-PROTECTORS				THERMISTORS	CONTROL	SPACE /n HEATERS
THERMOSTATS	PROTECTORS	WDG RTDs	BRG RTDs	NONE	FALSE	NONE VOLTS
NONE	NOT	NONE	NONE			

If Inverter equals NONE, contact factory for further information

\*  
N  
O  
T  
E  
S  
\*

INVERTER TORQUE: NONE
INV. HP SPEED RANGE: NONE
ENCODER: NONE
NONE NONE
NONE NONE PPR
BRAKE: NONE NONE
NONE P/N NONE
NONE NONE
NONE FT-LB NONE V NONE Hz

DATE: 06/23/2017 08:35:26 AM  
 FORM 3531 REV.3 02/07/99  
 \*\* Subject to change without notice.

Data Sheet

Date: 6/29/2017

284TTDN16101

Customer:  
Attention:

FAREEDA DUDEKULA



Submital  
Data @ 460 V

Load	Motor Load Data						
	0%	25%	50%	75%	100%	115%	125%
Current (Amps)	8.0	9.3	10.7	12.5	14.5	16.5	18.5
Torque (ft-lb)	0.00	14.5	29.5	44.5	59.7	69.0	75.5
RPM	900	895	890	885	880	875	870
Efficiency (%)		80.0	86.5	90.2	90.2	90.2	89.5
P.F. (%)	6.0	31.0	49.5	62.0	71.0	71.5	72.0
							28.5

Motor Speed Data

	LR	Pull-Up	BD	Rated	Idle
Speed (rpm)	0	500	825	880	900
Current (Amps)	70.0	65.0	50.0	14.5	8.0
Torque (ft-lb)	77.0	75.0	140	59.7	0.00

Information Block

HP	10.0
Sync. RPM	900
Frame	284
Enclosure	DP
Construction	TDN
Voltage	30/460#190/38 V
Frequency	60 Hz
Design	B
LR Code letter	G
Service Factor	1.15
Temp Rise @ FL	45 °C
Duty	CONT
Ambient	40 °C
Elevation	1,000 feet
Rotor/Shaft wk <sup>e</sup>	4.0 Lb-Fe
Rel Wdg	K284848 NONE
Sound Pressure @ 1M	63 dbA
VFD Rating	NONE
Outline Dwg	B-SS207/936-1325
Conn. Diag	A-EE7308
Additional Specifications:	
EQUIV CKT (OHMS/ PHASE)	
R1	R2
0.4830	0.4880
X1	X2
2.5730	3.8910
Xm	Xm
	29.9340

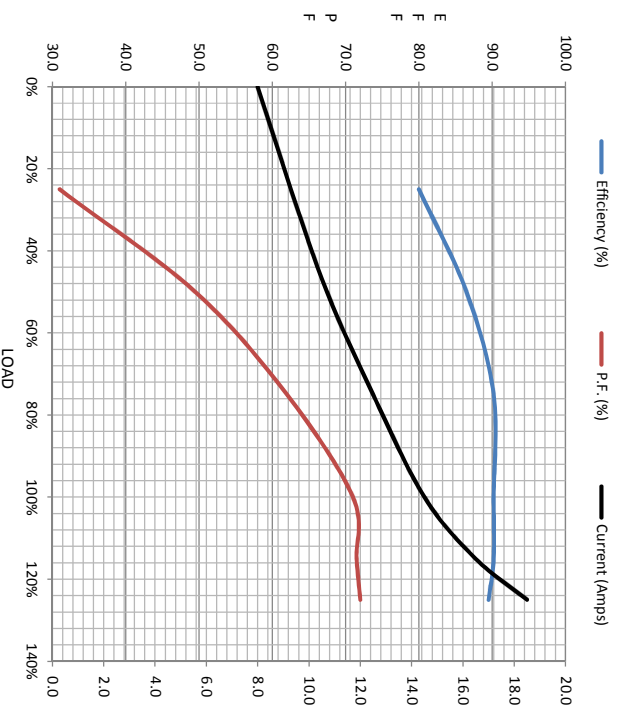

Speed -Torque Curve

